

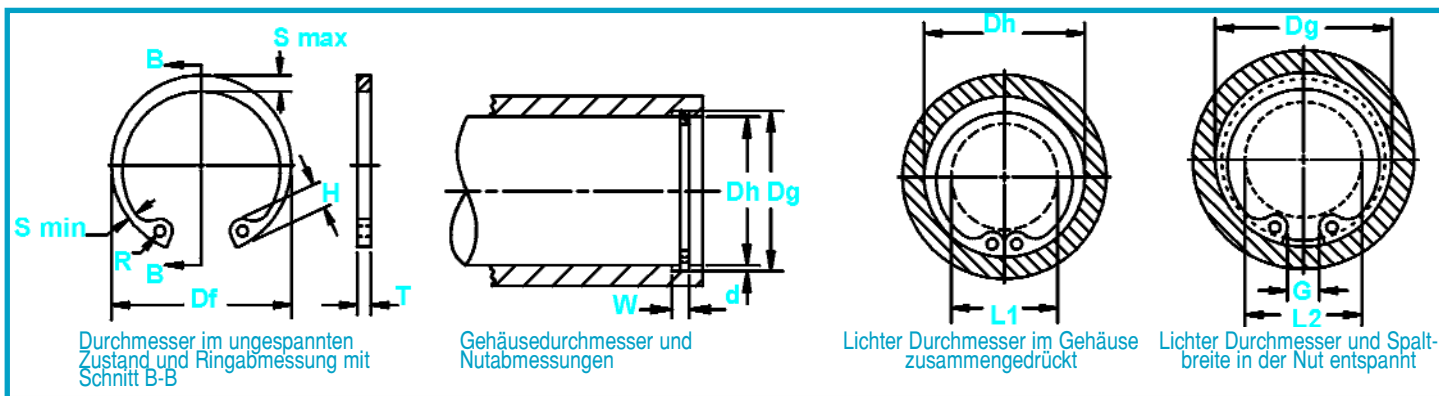

MHO Sicherungsringe für Bohrungen



RING NR.	GEHÄUSE DURCHMESSER		NUTGRÖÖE						RINGGRÖÖE UND GEWICHT				LICHTER DURCHM.		i AXIALBELASTUNG(kN) bei rechtwinkliger Anlage		
			DURCHMESSER			BREITE		TIEFE	Durchmesser im ungespannten Zustand		DICKE***		pro 1000 Stck.	Im Gehäuse zusammengeedrückt	In der Nut entspannt	Ring Sicherheitsfaktor 4	Nut Sicherheitsfaktor 2
	Ds mm	Ds INCH	Dg	tol	F.I.M.*	W	tol	d	Df	tol	T	tol	kg	L1	L2	Pr	Pg
MHO-8	8	0.315	8.40	+0.06	0.03	0.50	+0.10	0.20	8.80		0.4		0.05	4.4	4.8	2.4	1.0
MHO-9	9	0.354	9.45		0.03	0.70		0.23	10.00		0.6		0.11	4.6	5.0	4.4	1.2
MHO-10	10	0.393	10.50		0.03	0.70		0.25	11.10		0.6		0.14	5.5	6.0	4.9	1.5
MHO-11	11	0.433	11.60		0.05	0.70		0.30	12.20		0.6		0.17	5.7	6.3	5.4	2.0
MHO-12	12	0.472	12.65		0.05	0.70		0.33	13.30		0.6		0.19	6.7	7.3	5.8	2.4
MHO-13	13	0.512	13.70		0.05	1.00		0.35	14.25	+0.25	0.9		0.35	6.8	7.5	8.9	2.6
MHO-14	14	0.551	14.80	+0.10	0.05	1.00		0.40	15.45	-0.13	0.9		0.39	6.9	7.7	9.7	3.2
MHO-15	15	0.591	15.85		0.05	1.00		0.43	16.60		0.9		0.42	7.9	8.7	10.4	3.7
MHO-16	16	0.630	16.90		0.10	1.00		0.45	17.70		0.9		0.47	8.8	9.7	11.0	4.2
MHO-17	17	0.669	18.00		0.10	1.00		0.50	18.90		0.9		0.52	9.8	10.8	11.7	4.9
MHO-18	18	0.708	19.05		0.10	1.00		0.53	20.05		0.9		0.58	10.3	11.3	12.3	5.5
MHO-19	19	0.748	20.10		0.10	1.00		0.55	21.10		0.9		0.59	11.4	12.5	13.1	6.0
MHO-20	20	0.787	21.15		0.10	1.00		0.57	22.25		0.9		0.70	11.6	12.7	13.7	6.6
MHO-21	21	0.826	22.20		0.10	1.00	+0.15	0.60	23.30		0.9	+0.06	0.82	12.6	13.8	14.5	7.3
MHO-22	22	0.866	23.30		0.10	1.20		0.65	24.40		1.1		0.90	13.5	14.8	22.5	8.3
MHO-23	23	0.905	24.35	+0.15	0.10	1.20		0.67	25.45	+0.40	1.1		1.00	14.5	15.9	23.5	8.9
MHO-24	24	0.945	25.40		0.10	1.20		0.70	26.55	-0.25	1.1		1.09	15.5	16.9	24.8	9.7
MHO-25	25	0.984	26.60		0.10	1.20		0.80	27.75		1.1		1.26	16.5	18.1	25.7	11.6
MHO-26	26	1.023	27.70		0.15	1.20		0.85	28.85		1.1		1.3	17.5	19.2	26.8	12.7
MHO-27	27	1.063	28.80		0.15	1.40		0.90	29.95		1.3		1.7	17.4	19.2	33.0	14.0
MHO-28	28	1.102	29.80		0.15	1.40		0.90	31.10		1.3		1.8	18.2	20.0	34.0	14.6
MHO-30	30	1.181	31.90		0.15	1.40		0.95	33.40		1.3		2.0	20.0	21.9	37.0	16.5
MHO-32	32	1.260	33.90		0.15	1.40		0.95	35.35	+0.65	1.3		2.2	22.0	23.9	39.0	17.6
MHO-34	34	1.339	36.10		0.15	1.40		1.05	37.75	-0.50	1.3		2.3	24.0	26.1	42.0	20.6
MHO-35	35	1.378	37.20		0.15	1.40		1.10	38.75		1.3		2.3	25.0	27.2	43.0	22.3
MHO-36	36	1.417	38.30		0.15	1.40		1.15	40.00		1.3		2.6	26.0	28.3	44.0	23.9
MHO-37	37	1.457	39.30		0.15	1.40		1.15	41.05		1.3		2.9	27.0	29.3	45.0	24.6
MHO-38	38	1.496	40.40	+0.20	0.15	1.40		1.20	42.15		1.3		3.0	28.0	30.4	46.0	26.4
MHO-40	40	1.575	42.40		0.15	1.75		1.20	44.25		1.6		4.0	29.2	31.6	62.0	27.7
MHO-42	42	1.654	44.50		0.15	1.75		1.25	46.60		1.6		4.7	29.7	32.2	65.0	30.2
MHO-45	45	1.772	47.60		0.15	1.75		1.30	49.95	+0.90	1.6		5.1	32.3	34.9	69.0	33.8
MHO-46	46	1.811	48.70		0.20	1.75	+0.20	1.35	51.05	-0.65	1.6	+0.08	5.2	33.3	36.0	71.0	36.0
MHO-47	47	1.850	49.80		0.20	1.75		1.40	52.15		1.6		5.8	34.3	37.1	72.0	38.0
MHO-48	48	1.890	50.90		0.20	1.75		1.45	53.30		1.6		6.1	35.0	37.9	74.0	40.0
MHO-50	50	1.969	53.10		0.20	1.75		1.55	55.35		1.6		6.2	36.9	40.0	77.0	45.0

GESAMTER ANZEIGENAUSSCHLAG - MAXIMAL ZULÄSSIGE RUNDLAUFABWEICHUNG ZWISCHEN NUT UND GEHÄUSE

i BASIEREND AUF GEHÄUSEN/WELLEN AUS KALTGEWALZTEM STAHL. FRAGEN ZU DEN FORMELN, DIE ZUR ABLEITUNG DER AXIALBELASTUNG UND DER ANDEREN LEISTUNGSKENNDATEN VERWENDET WURDEN, BITTE AN DIE ABTEILUNG ROTOR CLIP ENGINEERING RICHTEN.

*** DIE AUFGEFÜHRTE MAXIMALE DICKE BEI GALVANISCH BEHANDELTEN RINGEN ZUZÜGLICH 0,05 mm. DIE MAXIMALE RINGDICKE IST UM MINDESTENS 0,005 mm KLEINER ALS DIE AUFGEFÜHRTE MINIMALE NUTBREITE (W).

Axialmontiert, für Bohrungen, ANSI Metrisch

Nachdem diese Ringe in die Nut einer Bohrung/Gehäuse gesetzt werden, legen Sie Bauteile mittels des Bundes fest.

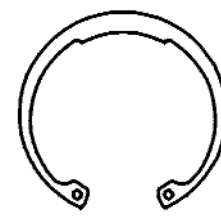
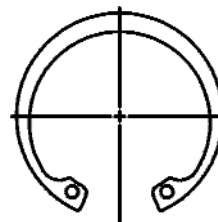
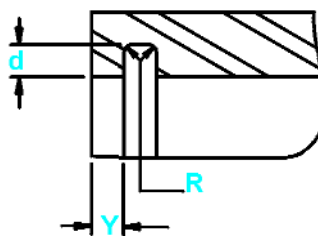
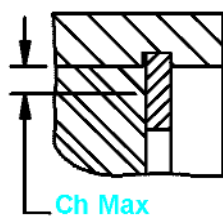
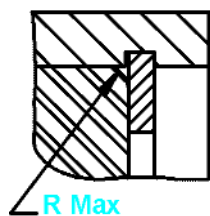

Zulässige Eckenrundung und Abschrägung

Auseinandergezogene Ansicht des Nutprofils und Kantenabstands(Y).

Max. Bodenradien(R), 0,10 für Ringgrößen -8 bis -17; 0,2 für Größen -18 bis 30; 0,3 für Größen 32 bis 55; 0,4 für Größen 56-250.

Alternative Augenausführung für größere Ringe (nach Wahl des Herstellers)

Alternative Ausführung (nach Wahl des Herstellers)

RING NR.	AUGEN HÖHE	MAXIMUM QUERSCHNITT	MINIMUM QUERSCHNITT	MONTAGELOCH DURCHMESSER	SPALT-BREITE Ring in Nut	ZULÄSSIGE ECKENRUNDUNG und ABSCHRÄGUNG		MAX. Belastung bei R max oder Ch max	KANTEN-ABSTAND
						R max	Ch max		
	H nom	S max/Ref.	S min/Ref.	R min	G			P'r	Y
MHO-8	1.7	0.85	0.45	0.8	1.40	0.4	0.3	0.8	0.6
MHO-9	2.1	1.25	0.65	1.0	1.50	0.5	0.35	2.0	0.7
MHO-10	2.1	1.30	0.70	1.0	1.85	0.5	0.35	2.0	0.8
MHO-11	2.5	1.30	0.70	1.0	1.95	0.6	0.4	2.0	0.9
MHO-12	2.5	1.35	0.75	1.0	2.25	0.6	0.4	2.0	1.0
MHO-13	2.9	1.35	0.90	1.2	2.35	0.7	0.5	4.0	1.1
MHO-14	3.3	1.60	0.90	1.2	2.65	0.7	0.5	4.0	1.2
MHO-15	3.3	1.65	0.95	1.5	2.80	0.7	0.5	4.0	1.3
MHO-16	3.4	1.70	0.95	1.5	2.80	0.7	0.5	4.0	1.4
MHO-17	3.4	1.70	0.95	1.5	3.35	0.75	0.6	4.0	1.5
MHO-18	3.6	1.80	1.00	1.5	3.40	0.75	0.6	4.0	1.6
MHO-19	3.6	1.80	1.00	1.5	3.40	0.8	0.65	4.0	1.7
MHO-20	4.0	2.00	1.10	1.5	3.80	0.9	0.7	4.0	1.7
MHO-21	4.0	2.10	1.20	1.5	4.20	0.9	0.7	4.0	1.8
MHO-22	4.0	2.10	1.20	1.5	4.30	0.9	0.7	7.4	1.9
MHO-23	4.0	2.20	1.20	1.5	4.90	1.0	0.8	7.4	2.0
MHO-24	4.0	2.30	1.30	1.5	5.20	1.0	0.8	7.4	2.1
MHO-25	4.0	2.60	1.30	1.5	6.00	1.0	0.8	7.4	2.4
MHO-26	4.0	2.70	1.40	1.5	5.70	1.2	1.0	7.4	2.6
MHO-27	4.6	2.80	1.40	1.9	5.90	1.2	1.0	10.8	2.7
MHO-28	4.6	2.90	1.50	1.9	6.00	1.2	1.0	10.8	2.7
MHO-30	4.6	3.00	1.50	1.9	6.00	1.2	1.0	10.8	2.9
MHO-32	4.6	3.10	1.60	1.9	7.30	1.2	1.0	10.8	2.9
MHO-34	4.6	3.20	1.60	1.9	7.60	1.2	1.0	10.8	3.2
MHO-35	4.6	3.30	1.60	1.9	8.00	1.2	1.0	10.8	3.3
MHO-36	4.6	3.40	1.70	1.9	8.30	1.2	1.0	10.8	3.5
MHO-37	4.6	3.40	1.70	1.9	8.40	1.2	1.0	10.8	3.5
MHO-38	4.6	3.40	1.70	1.9	8.60	1.2	1.0	10.8	3.6
MHO-40	5.1	4.00	2.00	1.9	9.70	1.7	1.3	17.4	3.6
MHO-42	5.8	4.20	2.10	1.9	9.00	1.7	1.3	17.4	3.7
MHO-45	6.0	4.30	2.10	1.9	9.60	1.7	1.3	17.4	3.9
MHO-46	6.0	4.30	2.10	2.3	9.70	1.7	1.3	17.4	4.0
MHO-47	6.0	4.30	2.20	2.3	10.00	1.7	1.3	17.4	4.2
MHO-48	6.0	4.50	2.30	2.3	10.50	1.7	1.3	17.4	4.3
MHO-50	6.0	4.60	2.30	2.3	12.10	1.7	1.3	17.4	4.6

HÄRTEANGABEN SIEHE ENDE DIESES ABSCHNITTS.



MHO Sicherungsringe für Bohrungen

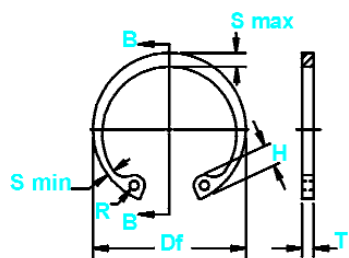

Durchmesser im ungespannten Zustand und Ringabmessung mit Schnitt B-B

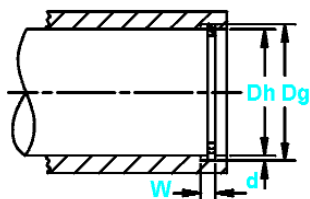

Gehäusedurchmesser und Nutabmessungen

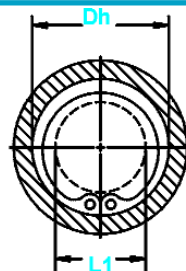

Lichter Durchmesser im Gehäuse zusammengedrückt

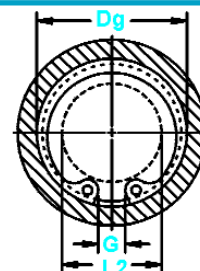

Lichter Durchmesser und Spaltbreite in der Nut entspannt

RING NR.	GEHÄUSE DURCHMESSER		NUTGRÖÖE						RINGGRÖÖE UND GEWICHT				LICHTER DURCHM.		i AXIALBELASTUNG (kN) bei rechtwinkliger Anlage		
			DURCHMESSER		BREITE		TIEFE	Durchmesser im ungespannten Zustand		DICKE***		Gewicht Pro 1000 Stck.	Im Gehäuse zusammen gedrückt	In der Nut entspannt	Ring Sicherheitsfaktor 4	Nut Sicherheitsfaktor 2	
	Ds mm	Ds INCH	Dg	tol	F.I.M.*	W	tol	d	Df	tol	T	tol	kg	L1	L2	Pr	Pg
MHO-52	52	2.047	55.30		0.20	2.15		1.65	57.90		2.0		8.1	38.6	41.9	99.0	50.0
MHO-55	55	2.165	58.40		0.20	2.15		1.70	61.10		2.0		8.9	40.8	44.2	105.0	54.0
MHO-57	57	2.244	60.50		0.20	2.15		1.75	63.25		2.0		9.9	42.2	45.7	109.0	58.0
MHO-58	58	2.283	61.60		0.20	2.15		1.80	64.40		2.0		10.1	43.2	46.8	111.0	60.0
MHO-60	60	2.362	63.80		0.20	2.15		1.90	66.80		2.0		10.5	45.5	49.3	115.0	66.0
MHO-62	62	2.441	65.80		0.20	2.15		1.90	68.60	+1.00	2.0	±0.08	11.5	47.0	50.8	119.0	68.0
MHO-63	63	2.480	66.90		0.20	2.15	+0.20	1.95	69.90	-0.75	2.0		11.6	47.8	51.7	120.0	71.0
MHO-65	65	2.559	69.00		0.20	2.55		2.00	72.20		2.4		15.4	49.4	53.4	149.0	75.0
MHO-68	68	2.677	72.20		0.20	2.55		2.10	75.70		2.4		15.9	52.0	56.2	156.0	82.0
MHO-70	70	2.756	74.40	+0.30	0.20	2.55		2.20	77.50		2.4		16.1	53.8	58.2	161.0	88.0
MHO-72	72	2.835	76.50		0.20	2.55		2.25	79.60		2.4		16.3	55.9	60.4	166.0	93.0
MHO-75	75	2.953	79.70		0.20	2.55		2.35	83.30		2.4		19.3	58.2	62.9	172.0	101.0
MHO-78	78	3.071	82.80		0.20	2.95		2.40	86.80		2.8		24.0	61.2	66.0	209.0	108.0
MHO-80	80	3.150	85.00		0.20	2.95		2.50	89.10		2.8		25.9	63.0	68.0	215.0	115.0
MHO-82	82	3.228	87.20		0.25	2.95		2.60	91.10	+1.40	2.8		27.2	63.5	68.7	220.0	122.0
MHO-85	85	3.346	90.40		0.25	2.95		2.70	94.40	-1.40	2.8		29.5	66.8	72.2	228.0	131.0
MHO-88	88	3.464	93.60		0.25	2.95		2.80	97.90		2.8		31.3	69.6	75.2	236.0	141.0
MHO-90	90	3.543	95.70		0.25	2.95		2.85	100.00		2.8		32.6	71.6	77.3	241.0	147.0
MHO-92	92	3.622	97.80		0.25	2.95		2.90	102.20		2.8		33.1	73.6	79.4	247.0	153.0
MHO-95	95	3.740	101.00		0.25	2.95		3.00	105.60		2.8		35.4	76.7	82.7	255.0	164.0
MHO-98	98	3.858	104.20		0.25	2.95		3.10	109.00		2.8		39.4	78.3	84.5	263.0	174.0
MHO-100	100	3.937	106.30		0.25	2.95		3.15	110.70		2.8		39.9	80.3	86.6	269.0	181.0
MHO-102	102	4.016	108.40		0.25	2.95		3.20	112.40		2.8		42.2	82.2	88.6	273.0	187.0
MHO-105	105	4.134	111.50		0.25	2.95		3.25	115.80		2.8		44.0	85.1	91.6	281.0	196.0
MHO-108	108	4.252	114.60		0.25	2.95		3.30	119.20		2.8		45.8	88.1	94.7	290.0	205.0
MHO-110	110	4.331	116.70		0.25	2.95		3.35	120.80	+1.65	2.8		47.6	88.4	95.1	295.0	212.0
MHO-115	115	4.528	121.90		0.25	2.95		3.45	126.00	-1.65	2.8		50.3	93.2	100.1	309.0	227.0
MHO-120	120	4.724	127.00		0.25	2.95		3.50	132.40		2.8		56.2	98.2	105.2	321.0	241.0
MHO-125	125	4.921	132.10	+0.40	0.25	2.95		3.55	137.10		2.8		60.0	103.1	110.2	335.0	255.0
MHO-130	130	5.118	137.20		0.25	2.95		3.60	142.50		2.8		63.5	108.0	115.2	349.0	269.0
MHO-135	135	5.315	142.30		0.25	3.40		3.65	148.50		3.2		79	110.4	117.7	415.0	283.0
MHO-140	140	5.512	147.40		0.25	3.40		3.70	154.10		3.2		83	115.3	122.7	429.0	298.0
MHO-145	145	5.709	152.50		0.25	3.40		3.75	159.50		3.2	±0.10	87	120.4	127.9	444.0	313.0
MHO-150	150	5.906	157.60		0.25	3.40		3.80	164.50		3.2		89	125.3	132.9	460.0	327.0
MHO-155	155	6.102	162.70		0.30	3.40		3.85	168.80		3.2		91	130.4	138.1	475.0	343.0
MHO-160	160	6.299	167.80		0.30	4.25		3.90	175.10		4.0		121	133.8	141.6	613.0	359.0
MHO-165	165	6.496	172.90		0.30	4.25		3.95	180.30	+2.05	4.0		127	138.7	146.6	632.0	374.0
MHO-170	170	6.693	178.00		0.30	4.25		4.00	185.60	-2.05	4.0		138	143.6	151.6	651.0	390.0
MHO-175	175	6.890	183.20		0.30	4.25	+0.25	4.10	191.30		4.0		147	146.0	154.2	670.0	403.0
MHO-180	180	7.087	188.40		0.30	4.25		4.20	196.60		4.0		156	151.4	159.8	690.0	434.0
MHO-185	185	7.283	193.60		0.30	5.10		4.30	202.70		4.8		194	154.7	163.3	851.0	457.0
MHO-190	190	7.480	198.80		0.30	5.10		4.40	207.70		4.8	±0.12	220	159.5	168.3	873.0	480.0
MHO-200	200	7.874	209.00	+0.50	0.30	5.10		4.50	217.80		4.8		235	169.2	178.2	919.0	517.0
MHO-210	210	8.268	219.40		0.30	5.10		4.70	230.30	+2.30	4.8		275	177.5	186.9	965.0	566.0
MHO-220	220	8.661	230.00		0.30	5.10		5.00	240.50	-2.30	4.8		285	184.1	194.1	1000.0	608.0
MHO-230	230	9.055	240.60		0.30	5.10		5.30	251.40		4.8		330	194.0	204.6	1060.0	686.0
MHO-240	240	9.449	251.00		0.30	5.10		5.50	262.30		4.8		365	200.4	211.4	1090.0	725.0
MHO-250	250	9.843	261.40		0.30	5.10		5.70	273.30		4.8		375	210.0	221.4	1150.0	808.0

*GESAMTER ANZEIGENAUSSCHLAG -MAXIMAL ZULÄSSIGE RUNDLAUFABWEICHUNG ZWISCHEN NUT UND GEHÄUSE
 †BASIEREND AUF GEHÄUSEN/WELLEN AUS KALTGEWALZTEM STAHL. FRAGEN ZU DEN FORMELN, DIE ZUR ABLEITUNG DER AXIALBELASTUNG UND DER ANDEREN LEISTUNGSKENNDA TEN VERWENDET WURDEN, BITTE AN DIE ABTEILUNG ROTOR CLIP ENGINEERING RICHTEN.
 *** DIE AUFGEFÜHRTE MAXIMALE DICKE BEI GALVANISCH BEHANDELTEN RINGEN ZUZÜGLICH 0,05 mm. DIE MAXIMALE RINGDICKE IST UM MINDESTENS 0,005 mm KLEINER ALS DIE AUFGEFÜHRTE MINIMALE NUTBREITE (W).

Axialmontiert, für Bohrungen, ANSI Metrisch

Nachdem diese Ringe in die Nut einer Bohrung/Gehäuse gesetzt werden, legen sie Bauteile mittels des Bundes fest.

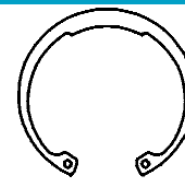
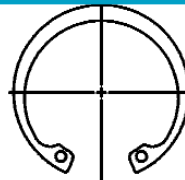
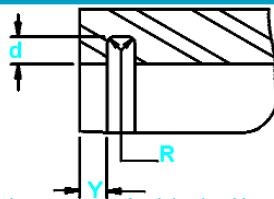
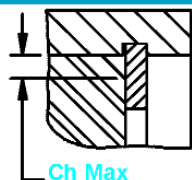
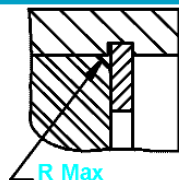

Zulässige Eckenrundung und Abschrägung

Auseinandergezogene Ansicht des Nutprofils und Kantenstands(Y). Max.Bodenradien(R), 0,10 für Ringgrößen -8 bis -17; 0,2 für Größen -18 bis 30; 0,3 für Größen 32 bis 55; 0,4 für Größen 56-250.

Alternative Augenausführung für größere Ringe (nach Wahl des Herstellers)

Alternative Ausführung (nach Wahl des Herstellers)

RING NR.	AUGEN HOHE	MAXIMUM QUERSCHNITT	MINIMUM QUERSCHNITT	MONTAGELOCH DURCHMESSER	SPALT-BREITE Ring in Nut	ZULÄSSIGE ECKENRUNDUNG und ABSCHRÄGUNG		MAX. Belastung bei R max oder Ch max	KANTEN-ABSTAND
						R max	Ch max		
	H nom	S max/Ref.	S min/Ref.	R min	G			P'r	Y
MHO-52	6.4	4.70	2.30	2.3	11.70	2.0	1.6	27.4	5.0
MHO-55	6.7	5.10	2.50	2.3	11.90	2.0	1.6	27.4	5.1
MHO-57	6.9	5.20	2.50	2.3	12.50	2.0	1.6	27.4	5.3
MHO-58	6.9	5.30	2.60	2.3	13.00	2.0	1.6	27.4	5.4
MHO-60	6.9	5.30	2.60	2.3	12.70	2.0	1.6	27.4	5.7
MHO-62	7.1	5.30	2.60	2.7	14.00	2.0	1.6	27.4	5.7
MHO-63	7.1	5.40	2.70	2.7	14.20	2.0	1.6	27.4	5.9
MHO-65	7.4	5.60	2.80	2.7	14.20	2.0	1.6	42.0	6.0
MHO-68	7.6	5.80	2.90	2.7	14.40	2.3	1.8	39.0	6.3
MHO-70	7.6	5.80	2.90	2.7	16.10	2.3	1.8	39.0	6.6
MHO-72	7.6	5.80	2.90	2.7	17.40	2.3	1.8	39.0	6.7
MHO-75	7.9	6.20	3.10	2.7	16.80	2.3	1.8	54.0	7.1
MHO-78	7.9	6.50	3.20	3.1	17.60	2.5	2.0	54.0	7.2
MHO-80	7.9	6.70	3.30	3.1	17.20	2.5	2.0	54.0	7.5
MHO-82	8.7	6.90	3.40	3.1	18.80	2.6	2.1	54.0	7.8
MHO-85	8.7	7.00	3.60	3.1	19.10	2.6	2.1	54.0	8.1
MHO-88	8.7	7.30	3.60	3.1	20.40	2.8	2.2	54.0	8.4
MHO-90	8.7	7.40	3.60	3.1	21.40	2.8	2.2	54.0	8.6
MHO-92	8.7	7.60	3.80	3.1	22.20	2.9	2.4	54.0	8.7
MHO-95	8.7	7.80	3.90	3.1	22.60	3.0	2.5	54.0	9.0
MHO-98	9.4	8.10	4.10	3.1	22.60	3.0	2.5	54.0	9.3
MHO-100	9.4	8.20	4.10	3.1	24.10	3.1	2.5	54.0	9.5
MHO-102	9.4	8.40	4.20	3.1	25.50	3.2	2.6	54.0	9.6
MHO-105	9.4	8.40	4.30	3.1	26.00	3.3	2.6	54.0	9.8
MHO-108	9.4	8.50	4.60	3.1	26.40	3.5	2.7	54.0	9.9
MHO-110	10.3	8.70	4.60	3.8	27.50	3.6	2.8	54.0	10.1
MHO-115	10.3	8.90	4.60	3.8	29.40	3.7	2.9	54.0	10.4
MHO-120	10.3	9.40	4.60	3.8	27.20	3.9	3.1	54.0	10.5
MHO-125	10.3	9.50	4.70	3.8	30.30	4.0	3.2	54.0	10.7
MHO-130	10.3	9.80	4.90	3.8	31.00	4.0	3.2	54.0	10.8
MHO-135	11.6	10.40	5.00	3.8	30.40	4.3	3.4	67.0	11.0
MHO-140	11.6	10.40	5.00	3.8	30.40	4.3	3.4	67.0	11.1
MHO-145	11.6	10.60	5.30	3.8	31.60	4.3	3.4	67.0	11.3
MHO-150	11.6	10.80	5.40	3.8	33.50	4.3	3.4	67.0	11.4
MHO-155	11.6	10.80	5.40	3.8	37.00	4.3	3.4	67.0	11.6
MHO-160	12.3	10.90	5.40	4.6	35.00	4.5	3.6	102.0	11.7
MHO-165	12.3	11.10	5.60	4.6	33.10	4.6	3.7	102.0	11.9
MHO-170	12.3	11.40	5.60	4.6	38.20	4.6	3.7	102.0	12.0
MHO-175	13.5	11.60	5.70	4.6	37.70	4.8	3.8	102.0	12.3
MHO-180	13.5	12.00	5.90	4.6	39.00	5.0	4.0	102.0	12.6
MHO-185	14.2	12.40	6.00	4.6	37.30	5.1	4.1	151.0	12.9
MHO-190	14.2	12.90	6.30	4.6	35.00	5.3	4.3	151.0	13.2
MHO-200	14.2	13.30	6.50	4.6	43.90	5.4	4.3	151.0	13.5
MHO-210	15.2	14.20	6.90	4.6	40.60	5.8	4.6	151.0	14.1
MHO-220	16.8	15.00	7.30	4.6	38.30	6.1	4.9	151.0	15.0
MHO-230	16.8	15.50	7.50	4.6	49.00	6.3	5.1	151.0	15.9
MHO-240	18.7	16.30	7.70	4.6	45.40	6.6	5.3	151.0	16.5
MHO-250	18.7	16.70	7.80	4.6	53.00	6.7	5.4	151.0	17.1

HÄRTEBEREICH: EDELSTAHLRINGE (PH 15-7MO)

RINGSORTE	GRÖßENBEREICH	SKALA	ROCKWELL-HÄRTE
MHO	8	15N	82.5-86
	9-26	30N	63-69.5
	27-250	C	44-51

HÄRTEBEREICH: KOHLENSTOFFSTAHL-RINGE (SAE 1060-1090)

RINGSORTE	GRÖßENBEREICH	SKALA	ROCKWELL-HÄRTE
MHO	8	15N	86-88
	9-13	30N	69.5-73
	14-20	30N	68.5-72
	21-26	30N	67.5-71
	27-250	C	48-52

Für die aktuellsten Angaben, Online-Preisangebote & Musterbestellungen, besuchen Sie rotorclip.com