



# ME Shaft Rings

## Radially Assembled, External 'E', ANSI Metric

Perhaps the most popular and widely used radial retaining ring is the "E" (so named because it is shaped like the letter "E").

Three prongs make contact with the bottom of the groove and provide a shoulder for effective retention of assemblies.

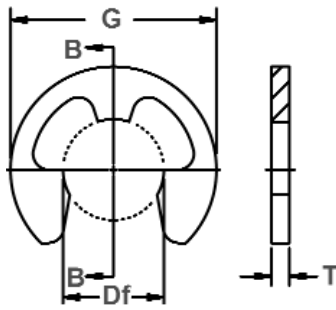

Free Diameter & Ring Measurements  
With Section B-B

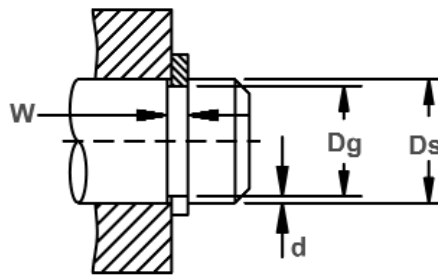

Shaft Diameter &  
Groove Dimensions

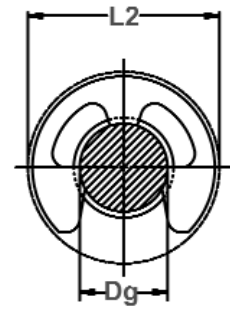

Clearance Diameter &  
Installed In Groove

RING NO.	SHAFT DIAMETER		GROOVE SIZE					RING SIZE & WEIGHT					CLEARANCE DIA.		i THRUST LD (kN) Sqr. Corner Abutment		
	Ds mm	Ds DEC	DIAMETER		WIDTH	DEPTH	FREE DIAMETER		THICKNESS***	Wt. Per 1000 Pcs.	Free Out-Side Dia. Ref.	Re-leased In Groove	Ring (Safety factor of 3)	Groove (Safety factor of 2)			
			Dg	Tol.			F.I.M.**	Tol.							d	Df	Tol.
ME-1*	1	.039	0.72	-0.05	0.04	0.32	+0.05	0.14	0.64		0.25	±0.05	0.004	2.0	2.2	0.06	0.02
ME-2	2	.079	1.45		0.04	0.32		0.28	1.30		0.25		0.014	4.0	4.3	0.13	0.09
ME-3	3	.118	2.30		0.04	0.50	+0.10	0.35	2.10	+0.03	0.40		0.036	5.6	6.0	0.30	0.17
ME-4	4	.157	3.10	-0.08	0.05	0.70		0.45	2.90	-0.08	0.60		0.095	7.2	7.6	0.70	0.30
ME-5	5	.197	3.90		0.05	0.70		0.55	3.70		0.60		0.13	8.5	8.9	0.90	0.40
ME-6	6	.236	4.85		0.05	0.70		0.58	4.70		0.60		0.21	11.1	11.5	1.10	0.60
ME-7	7	.275	5.55		0.08	0.70		0.73	5.25		0.60		0.34	13.4	14.0	1.20	0.80
ME-8	8	.315	6.40		0.08	0.70		0.80	6.15		0.60		0.35	14.6	15.1	1.40	1.00
ME-9	9	.354	7.20	-0.10	0.08	1.00		0.90	6.80		0.90	±0.06	0.58	15.8	16.5	3.00	1.30
ME-10	10	.393	8.00		0.08	1.00	+0.15	1.00	7.60	+0.05	0.90		0.68	16.8	17.5	3.40	1.60
ME-11	11	.433	8.90		0.10	1.00		1.05	8.55	-0.10	0.90		0.68	17.4	18.0	3.70	1.90
ME-12	12	.472	9.60		0.10	1.20		1.20	9.20		1.10		1.00	18.6	19.3	4.90	2.30
ME-13	13	.512	10.30		0.10	1.20		1.35	9.95		1.10		1.13	20.3	21.0	5.40	2.90
ME-15	15	.591	11.80	-0.15	0.10	1.20		1.60	11.40		1.10		1.40	22.8	23.5	6.20	4.00
ME-16	16	.630	12.50		0.10	1.20		1.75	12.15		1.10		1.45	23.8	24.5	6.60	4.50
ME-18	18	.709	14.30		0.10	1.40		1.85	13.90	+0.10	1.30		2.3	27.2	27.9	8.70	5.40
ME-20	20	.787	16.00		0.10	1.40		2.00	15.60	-0.15	1.30		2.8	30.0	30.7	9.80	6.50
ME-22	22	.866	17.40	-0.20	0.10	1.40		2.30	17.00		1.30		3.4	33.0	33.7	10.80	8.10
ME-25	25	.984	20.00		0.10	1.40		2.50	19.50		1.30		4.2	37.1	37.9	12.20	10.10

\* AVAILABLE IN BERYLLIUM COPPER ONLY.

\*\* F.I.M. (FULL INDICATOR MOVEMENT)- MAXIMUM ALLOWABLE DEVIATION OF CONCENTRICITY BETWEEN GROOVE AND SHAFT.

i BASED ON GROOVES MADE OF COLD ROLLED STEEL. FOR AN EXPLANATION OF FORMULAS USED TO DERIVE THRUST LOAD AND OTHER PERFORMANCE DATA CONTACT THE ROTOR CLIP ENGINEERING DEPARTMENT.

\*\*\* FOR PLATED RINGS, ADD 0.05 TO THE LISTED MAXIMUM THICKNESS. MAXIMUM THICKNESS WILL BE A MINIMUM OF 0.005 LESS THAN THE LISTED GROOVE WIDTH (W) MINIMUM.

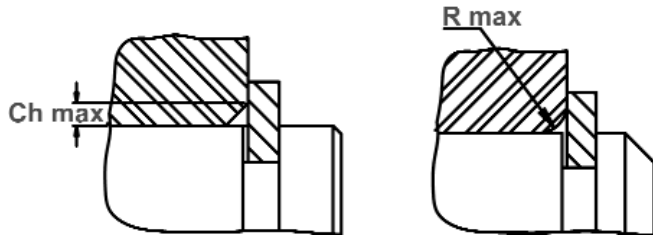

Maximum Corner Radius & Chamfer

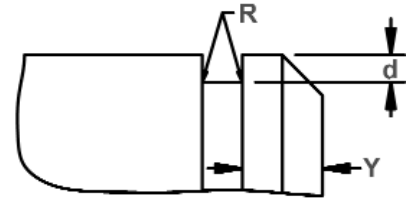

Exploded Groove Profile & Edge Margin (Y)  
 Maximum bottom radii (R), 0.05 for ring sizes  
 -1 thru -2; 0.15 for ring sizes -3 thru -7;  
 0.25 for ring sizes -8 thru -13  
 0.40 for ring sizes -15 thru -25

RING NO.	ALLOWABLE CORNER RADII & CHAMFERS		MAX. LOAD w/ R max or Ch max (kN)	EDGE MARGIN		R.P.M. LIMITS Standard Material
	R max	Ch max		P'r	Y	
ME-1*	0.4	0.25	0.06	0.3	40000	
ME-2	0.8	0.50	0.13	0.6	40000	
ME-3	1.1	0.70	0.30	0.7	34000	
ME-4	1.6	1.20	0.70	0.9	31000	
ME-5	1.6	1.20	0.90	1.1	27000	
ME-6	1.6	1.20	1.10	1.2	25000	
ME-7	1.6	1.20	1.20	1.5	23000	
ME-8	1.7	1.30	1.40	1.6	21500	
ME-9	1.7	1.30	3.00	1.8	19500	
ME-10	1.7	1.30	3.40	2.0	18000	
ME-11	1.7	1.30	3.70	2.1	16500	
ME-12	1.9	1.40	4.90	2.4	15000	
ME-13	2.0	1.50	5.40	2.7	13000	
ME-15	2.0	1.50	6.20	3.2	11500	
ME-16	2.0	1.50	6.60	3.5	10000	
ME-18	2.1	1.60	8.70	3.7	9000	
ME-20	2.2	1.70	9.80	4.0	8000	
ME-22	2.2	1.70	10.80	4.6	7000	
ME-25	2.4	1.90	12.20	5.0	5000	

LARGER SIZES MAY BE AVAILABLE UPON REQUEST.

HARDNESS RANGES: STAINLESS STEEL RINGS (PH 15-7MO)

RING TYPE	SIZE RANGE	SCALE	ROCKWELL HARDNESS
ME	2-3	15N	82.5-86*
	4-8	30N	63-69.5
	9-25	C	44-51

HARDNESS RANGES: BERYLLIUM COPPER RINGS

RING TYPE	SIZE RANGE	SCALE	ROCKWELL HARDNESS
ME	1-3	15N	79-82*
	4-9	30N	56.5-68
	10-25	C	37-43

HARDNESS RANGES: CARBON STEEL RINGS (SAE 1060-1090)

RING TYPE	SIZE RANGE	SCALE	ROCKWELL HARDNESS
ME	2-3	15N	85-87*
	4-8	30N	67.5-71
	9-25	C	48-52

\*HARDNESS CAN NOT BE CHECKED WITH ANY DEGREE OF ACCURACY DIRECTLY ON THESE RINGS.